

# Type 388 Butterfly Valve Installation and Maintenance Manual 2"-12"



## Installation Instructions

Type 388 butterfly valves are bi-directional, since control of fluid flow is equal in either direction, and are designed for installation between the faces of 125#/150# ANSI flanges. DO NOT USE GASKETS. The wafer bodies have locating lugs to ensure proper centering of the valve body when flange bolts are installed. Lug bodies have bolt hole locations same as mating flanges. Prior to installation, close the valve. Spread the flanges apart far enough to allow the valve to slip easily between the flanges. Insert the valve between the flanges. Be sure to center the valve and not damage the liner. Allow the flanges to return to their unspread state. Install and hand-tighten all flange bolts. Slowly open the valve, checking for free movement of the disc. If no obstruction is encountered, leave valve in the open position and tighten all flange bolts. Be certain to keep flange faces as parallel as possible during and after tightening bolts or studs. After final tightening, again check the valve for full opening and closing.

Lug style bodies used for dead end service must be installed as marked on the body (inlet-outlet).

## Maintenance

No regular maintenance or lubrication is required.

Item No	Part Name	Material
1A	Wafer Body	Cast Iron A126 CL.B Ductile Iron ASTM A536 65-45-12 Ductile Iron ASTM A395 60-40-18
1B	Lug Body	Cast Iron A126 CL.B Ductile Iron ASTM A536 65-45-12 Ductile Iron ASTM A395 60-40-18
2	Liner	EPDM NBR FPM PTFE
3	Disc	Ductile Iron ASTM A536 65-45-12 Aluminum Bronze ASTM B148 C95400 Stainless Steel ASTM A351
4	Drive Shaft	Stainless Steel ASTM A586 Type 416 Stainless Steel ASTM A276 Type 316
5	Bottom Shaft	Stainless Steel ASTM A586 Type 416 Stainless Steel ASTM A276 Type 316
6	Retaining Pin	Steel
7	Bearing	PTFE

Type 388 valves from George Fischer are equivalent to the Grinnell 8000 series ductile iron lug and cast iron wafer bodies.

## Valve Assembly

1. Clean all reusable parts.
2. Tap one bushing (7) from top of valve neck flange until it is about 1/4" from top surface. Tap the other in from inside the body seat bore into the bottom of the valve neck flange – about 1/4" from the bottom surface.
3. Apply a lubricant or soapy solution compatible with elastomers to facilitate assembly.
4. Insert liner (2) into body by pressing it into the body evenly. Be certain to line up the shaft holes and to place the elastomer free phenolic side of the liner so that it contacts the retention lip in the body when inserted on lug style bodies.
5. Insert disc (3) in open position into liner. Make certain broached end of disc is at the upper stem end of the body.
6. Coat the upper stem (4) with a general purpose lubricant and install into body.
7. Install bottom stem (5).
8. Install retaining pins (6).
9. Install the operator.
10. Check assembly by opening and closing the valve several times.
11. Follow installation instructions for reinstalling the valve in the piping system.

## Valve Disassembly

1. After removal of valve from the piping system, open the valve fully.
2. Remove the handle or actuator.
3. Remove the stem retaining pins (6).
4. Pull out the upper stem (4).
5. Pull out the bottom stem (5).
6. Remove the disc (3) from the liner (2), do not damage the disc edge.
7. Remove the liner (2).
8. Remove bushings (7), by tapping with blunt instrument.
9. Inspect all components for wear and replace as required.

# Type 388 Butterfly Valve Parts: 2"-12" Sizes

Item No	Part Name	Material
1A	Wafer Body	Cast Iron A126 Cl.B Ductile Iron ASTM A536 65-45-12 Ductile Iron ASTM A395 60-40-18
1B	Lug Body	Cast Iron A126 Cl.B Ductile Iron ASTM A536 65-45-12 Ductile Iron ASTM A395 60-40-18
2	Liner	EPDM NBR FPM PTFE
3	Disc	Ductile Iron ASTM A536 65-45-12 Aluminum Bronze ASTM B148 C95400 Stainless Steel ASTM A351
4	Drive Shaft	Stainless Steel ASTM A586 Type 416 Stainless Steel ASTM A276 Type 316
5	Bottom Shaft	Stainless Steel ASTM A586 Type 416 Stainless Steel ASTM A276 Type 316
6	Retaining Pin	Steel
7	Bearing	PTFE

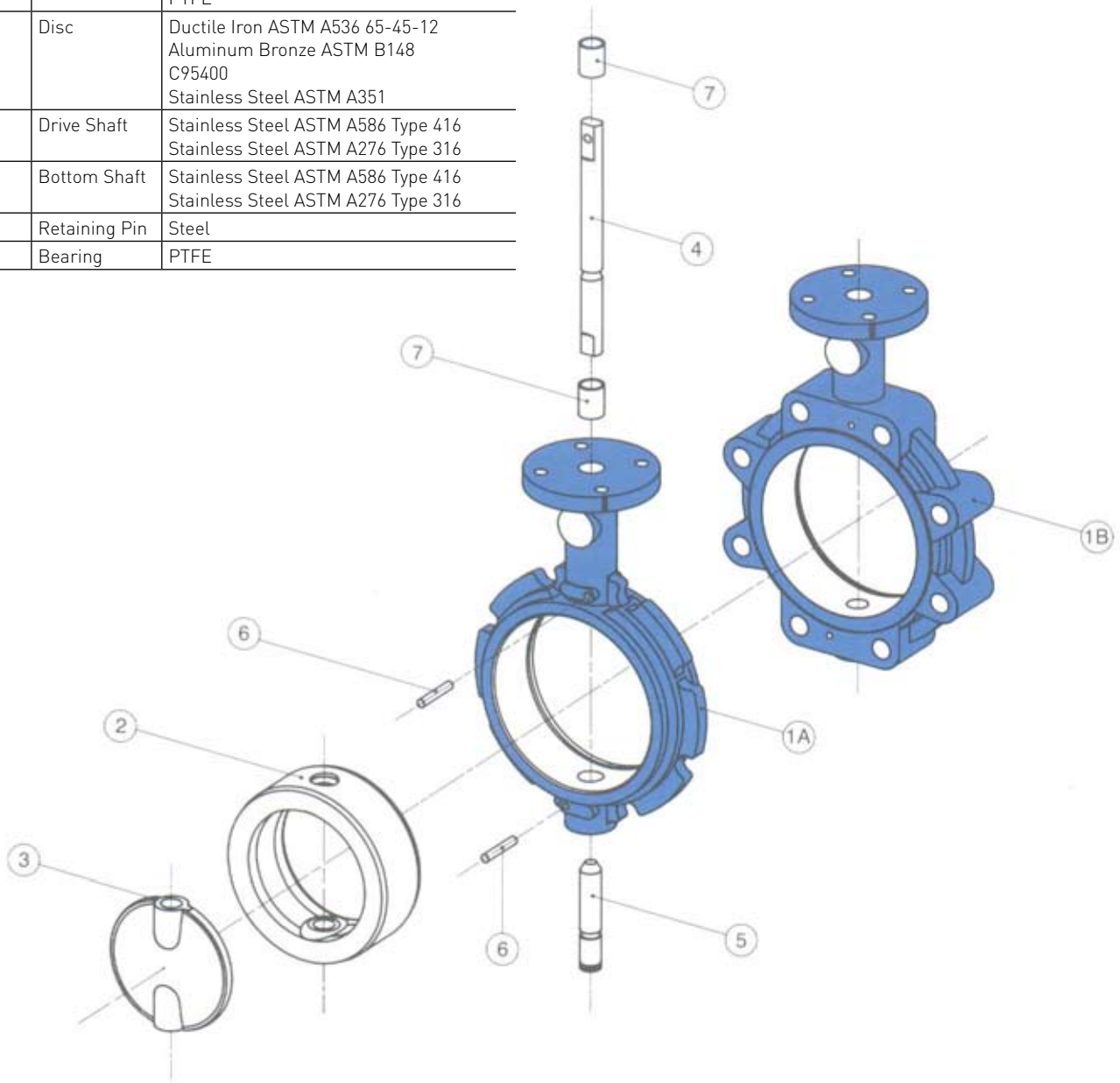

# Type 388 Butterfly Valve Installation and Maintenance Manual 14"-24"



## Installation Instructions

Type 388 butterfly valves are bi-directional, since control of fluid flow is equal in either direction, and are designed for installation between the faces of 125#/150# ANSI flanges. DO NOT USE GASKETS. The wafer bodies have locating lugs to ensure proper centering of the valve body when flange bolts are installed. Lug bodies have bolt hole locations same as mating flanges. Prior to installation, close the valve. Spread the flanges apart far enough to allow the valve to slip easily between the flanges. Insert the valve between the flanges. Be sure to center the valve and not damage the liner. Allow the flanges to return to their unspread state. Install and hand-tighten all flange bolts. Slowly open the valve, checking for free movement of the disc. If no obstruction is encountered, leave valve in the open position and tighten all flange bolts. Be certain to keep flange faces as parallel as possible during and after tightening bolts or studs. After final tightening, again check the valve for full opening and closing.

Lug style bodies used for dead end service must be installed as marked on the body (inlet-outlet).

## Maintenance

No regular maintenance or lubrication is required.

Item No	Part Name	Material
1A	Wafer Body	Cast Iron A126 Cl.B Ductile Iron ASTM A536 65-45-12 Ductile Iron ASTM A395 60-40-18
1B	Lug Body	Cast Iron A126 Cl.B Ductile Iron ASTM A536 65-45-12 Ductile Iron ASTM A395 60-40-18
2	Liner	EPDM NBR FPM PTFE
3	Disc	Ductile Iron ASTM A536 65-45-12 Aluminum Bronze ASTM B148 C95400 Stainless Steel ASTM A351
4	Drive Shaft	Stainless Steel ASTM A586 Type 416 Stainless Steel ASTM A276 Type 316
5	Bottom Shaft	Stainless Steel ASTM A586 Type 416 Stainless Steel ASTM A276 Type 316
6	Retaining Screw	Steel
7	Thrust Washer	Acetal
8	Plug	Cast Iron ASTM A126 Cl. B
9	Upper Bearing	PTFE
10	Lower Bearing	PTFE

Type 388 valves from George Fischer are equivalent to the Grinnell 8000 series ductile iron lug and cast iron wafer bodies.

## Valve Assembly

1. Clean all reusable parts.
2. Install the bearings (9 & 10) in the body. Align the hole in the upper bearing with the hole in the body (1) for the retaining screw (6).
3. Install liner (2) in the body (1) by locating the alignment rib on the liner with the alignment guide in the body and tapping the liner into the body.
4. Lubricate the sealing surfaces and the shaft holes of the liner with silicone lubricant.
5. Install the disc (3) in the open position.
6. Install the drive shaft (4).
7. Lubricate and install the bottom shaft (5).
8. Install the thrust washer (7).
9. Put a small amount of Loctite @242 or equivalent on the threads of the adjusting screw (8) and install the screw by turning it into the body until the bottom shaft contacts the disc. Do not over-tighten.
10. Install the retaining screw (6).
11. Follow installation instructions for re-installing the valve into the piping system.

## Valve Disassembly

1. After removal of valve from the piping system, open the valve fully.
2. Remove the operator.
3. Remove the adjusting plug (8).
4. Remove the thrust washer (7).
5. Remove the retaining screw (6).
6. Remove the bottom shaft (5).
7. Remove the drive shaft (4).
8. Remove the disc (3).
9. Remove the bearings (9 & 10) for wear. Remove if necessary.
10. Inspect the liner (2) for wear. Remove if necessary by tapping it out using a soft drift. Note: Liner can only be removed in the direction away from the retention lip on the body (1).
11. Inspect all components for wear and replace as necessary.

# Type 388 Butterfly Valve Parts: 14"-24" Sizes

Item No	Part Name	Material
1A	Wafer Body	Cast Iron A126 Cl.B Ductile Iron ASTM A536 65-45-12 Ductile Iron ASTM A395 60-40-18
1B	Lug Body	Cast Iron A126 Cl.B Ductile Iron ASTM A536 65-45-12 Ductile Iron ASTM A395 60-40-18
2	Liner	EPDM NBR FPM PTFE
3	Disc	Ductile Iron ASTM A536 65-45-12 Aluminum Bronze ASTM B148 C95400 Stainless Steel ASTM A351
4	Drive Shaft	Stainless Steel ASTM A586 Type 416 Stainless Steel ASTM A276 Type 316
5	Bottom Shaft	Stainless Steel ASTM A586 Type 416 Stainless Steel ASTM A276 Type 316
6	Retaining Screw	Steel
7	Thrust Washer	Acetal
8	Plug	Cast Iron ASTM A126 Cl. B
9	Upper Bearing	PTFE
10	Lower Bearing	PTFE

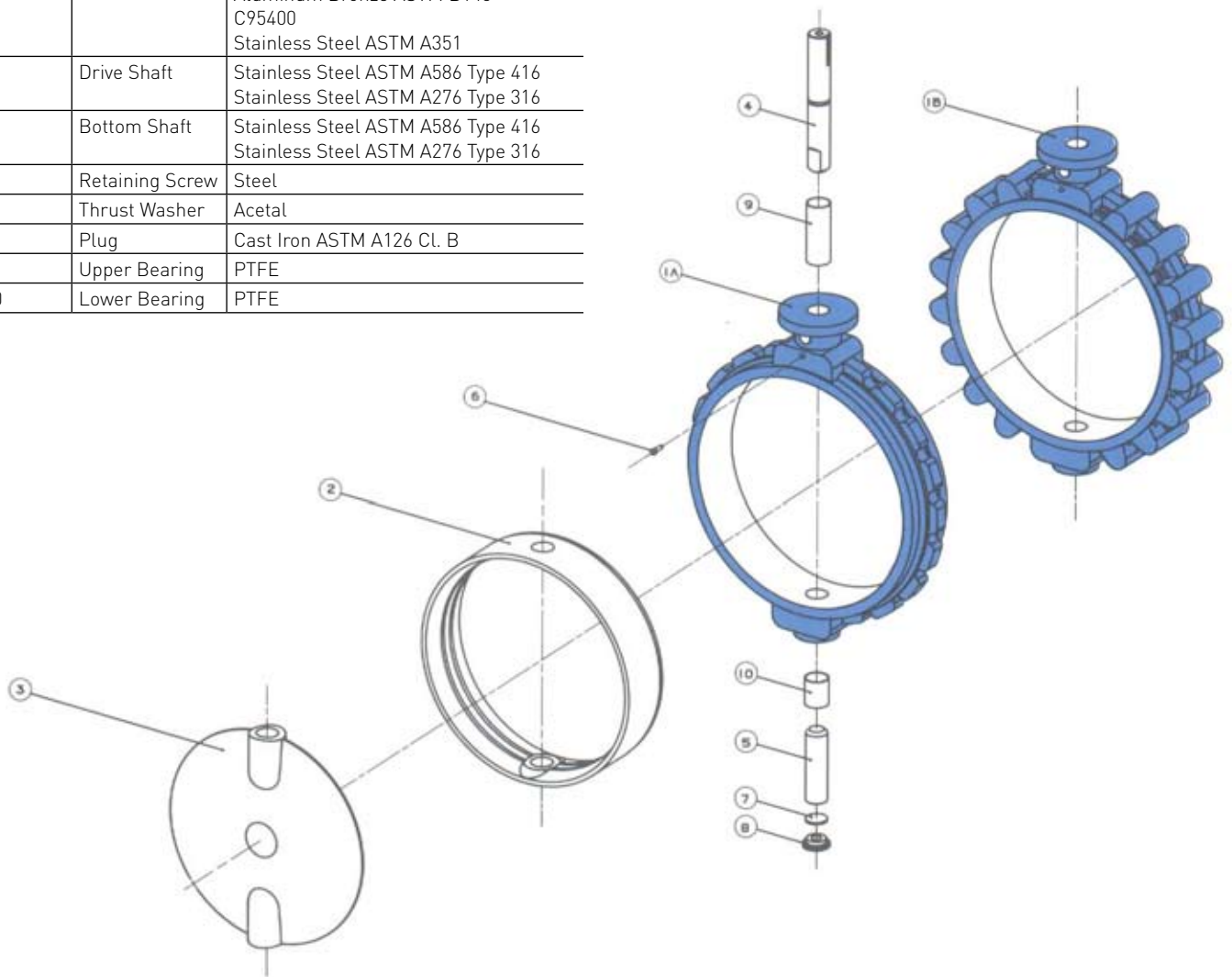

**GEORG FISCHER**  
PIPING SYSTEMS